

## Communication and Networking For Industrial Automation



Connectivity Solutions Plus, Inc. (CSP), An ISO 9001 Certified Manufacturer, Specializes In Industrial communication and networking for Harsh Industrial Applications Including Wireless I/O, Industrial Grade Wireless Gateways, Gateways, Industrial IoT, PLC Communication Using license free frequency bands As Well As 3G/4G Based Cell Based Technologies including:

- ◆ Wireless I/O Devices for cable-free transmission of analog and digital sensor I/Os
- ◆ Wireless Communication Devices For PLC Connectivity Including Profibus, Modbus, CAN And Others
- ◆ Routers Gateways for 3G and 4G LTE applications
- ◆ Cloud Based Remote Monitoring Systems
- ◆ Charging solutions for Electrical Cars

CSP Specializes In Matching Application Needs With The Right Communication Technologies For End-Users And OEMs. We Are Flexible By Design, Providing A Wide Range Of communication and networking solutions, Field-Configurable Systems, Exceptional Customer Service, And Custom Product Modifications.

Our solutions have been used In Many Industries Including Water And Wastewater Management, Oil And Gas, Manufacturing, Pharmaceuticals, Energy, Food Manufacturing And Agricultural Applications To Name A Few. Applications include:

- ◆ High-level alarms
- ◆ Security gate control
- ◆ Emergency level notification
- ◆ Flow meter monitoring
- ◆ Storage, tank monitoring
- ◆ Pipeline cathodic protection
- ◆ Pump stop-start
- ◆ Lighting bank control
- ◆ Power reticulation
- ◆ Relay fault notifications,
- ◆ Weather reporting station
- ◆ Bearing condition monitoring

## 905U-L Wireless I/O

ONE-WAY WIRELESS I/O UP TO 20 MILES



- ◆ Powerful, flexible, easy to use - No Software needed
- ◆ Plug N Play out of the Box
- ◆ Small I/O capability - use where a simple one-way link is required.
- ◆ Transmitter and receiver units are factory-configured as matched pairs, or user-configurable as part of a larger wireless I/O network
- ◆ Secure data Encryption
- ◆ Power supply 9 – 30VDC, 24VDC
- ◆ RS232 Configuration and diagnostics port
- ◆ Class 1 Div 2 hazardous areas approval

## 905U-K Wireless I/O

ONE-WAY, LOW I/O COUNT, PLUG N PLAY



- ◆ 902–928 MHz frequency and up to 1W RF power
- ◆ Link process inputs to single or multiple outputs (peer to peer)
- ◆ Peer-to-peer communications with exception reporting, reliable self-checking via update time, and secure data encryption
- ◆ External inputs plus internally calculated values, including analog set point status, pulse rate and pulse total, power/ battery supply voltage, and power supply alarm
- ◆ Can connect to up/down counter transducers, such as shaft-encoders
- ◆ Configurable repeat transmissions to enhance message reliability
- ◆ Set point, pulse count, and rate available. Additional Internal I/O points provided for health monitoring
- ◆ Class I Div 2 hazardous areas approval (US/Canada)

## 905U-1,2,3,4 Wireless Multi-I/O

BI-DIRECTIONAL UP TO 20 MILES



- ◆ Reasonable realization of data converters
- ◆ Saves additional data loggers
- ◆ Saves additional industrial PCs
- ◆ Realizing control functions in the router
- ◆ Replaces external devices with memory or computing power
- ◆ Simple to deploy, Long Range

# INSYS Powerline GP

## SMART CHARGING WITH HOMEPLUG GREEN PHY



- ◆ Communication via powerline standard HomePlug Green PHYTM
- ◆ Coupling of the powerline Green PHYTM signal to the pilot line
- ◆ Version with SLAC protocol as per ISO 15118-3 available
- ◆ Coupling of the powerline signal to the powerline (on request)
- ◆ Extended temperature range
- ◆ Designed for DIN rail mounting
- ◆ Enclosures for Outdoors and Ex rated environment available

### Application:

Communication between electric vehicle (PEV) and charging station (EVSE) as per ISO 15118 via powerline standard HomePlug Green PHY

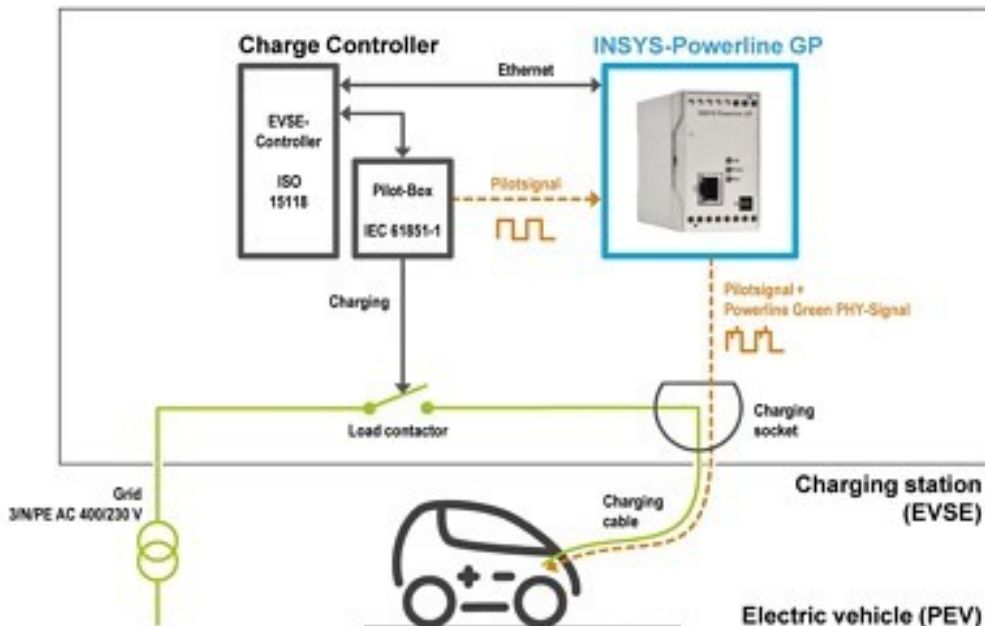
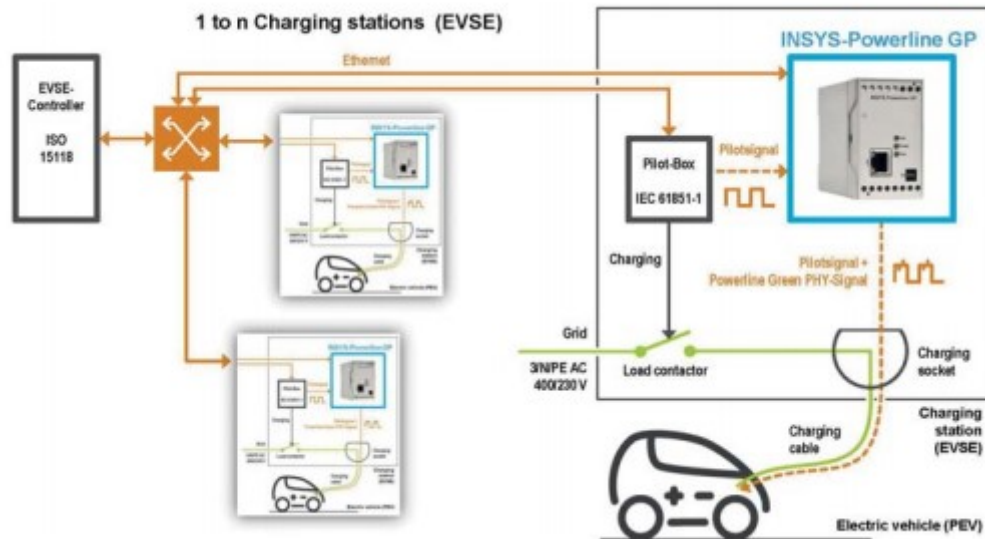

# MRO-L210: Industrial LTE Router

## Compact IoT/LTE Router



- ◆ 4G LTE, UMTS/HSPA, GPRS/EDGE
- ◆ 2x antenna connections (MIMO)
- ◆ 5-port switch 10/100BT
- ◆ 1x serial RS232/V.24/V.28
- ◆ 2 digital inputs + 1 digital output
- ◆ RS232 interface
- ◆ Integrated SmartBox, a Linux environment based on LXC technology
- ◆ Heavy-duty enclosures for outdoor and Ex-rated available

### Applications:

The professional router MRO-L210 is the compact power pack for your cellular (LTE) M2M and IoT applications. The router provides an operating system-independent platform, for example for local storage and processing of data or executing further programs and scripts (edge computing).

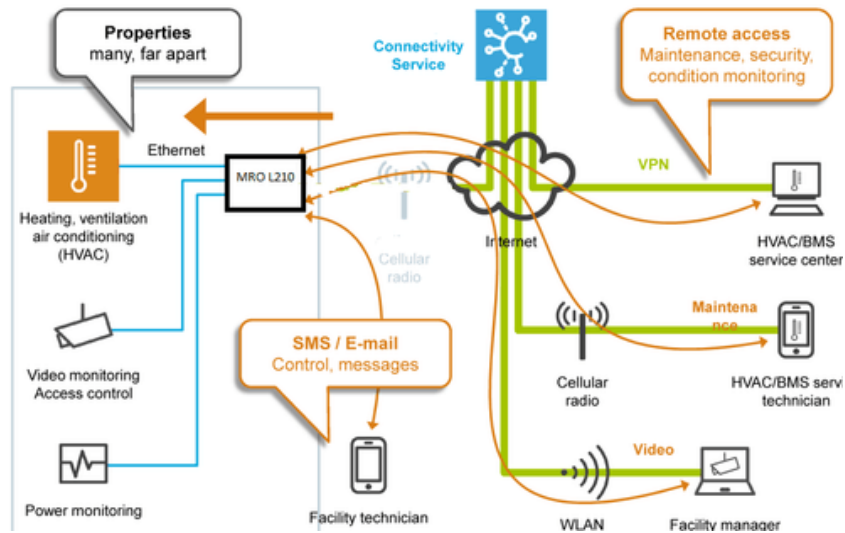

# MRX Series Modular Industrial LTE IoT Routers

FLEXIBLE. POWERFUL. FUTURE-PROOF



- ◆ MRX3/5 4G LTE Technology
- ◆ Ethernet module with 5 LAN ports
- ◆ Fully Modular
- ◆ LTE module with integrated power supply
- ◆ 2 digital inputs (1x PLC-capable)
- ◆ Heavy-duty enclosures for outdoor and Ex-rated available
- ◆ Fully Flexible- 1 or 3 free slots for MR cards
- ◆ Parallel operation of several apps on one router
- ◆ Completely independent of router firmware and configuration
- ◆ Own IP and MAC address per Linux Container
- ◆ Direct communication between the containers (e.g. via APIs)
- ◆ Encryption possible (e.g. know-how protection)

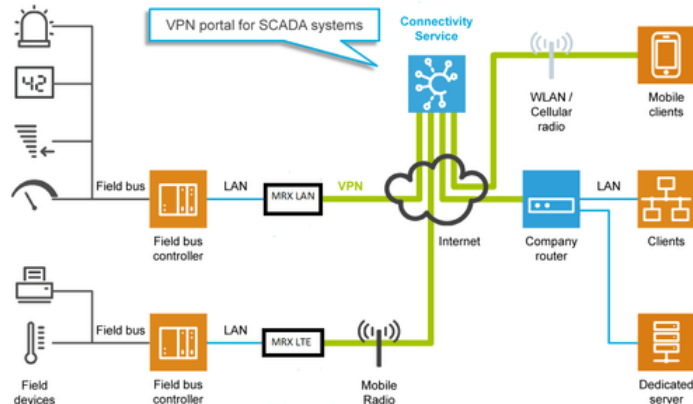

# IMON-U310

3G FAULT MONITOR MODBUS TCP/RTU AND SIEMENS PLCS



- ◆ 3G fault monitor with VPN functionality
- ◆ Monitoring of I/Os and Siemens LOGO! and Modbus TCP/RTU devices
- ◆ Alarming via SMS and e-mail
- ◆ Visualizing monitored values and registers
- ◆ 1 LAN interface, 2 serial interfaces (RS232/RS485)
- ◆ 2 x 2 digital inputs and outputs
- ◆ Heavy-duty enclosures for outdoor and Ex-rated available
- ◆ Open for own applications (Linux sandbox)
- ◆ Quick start for our Connectivity Service
- ◆ Optional monitoring package for Siemens S7

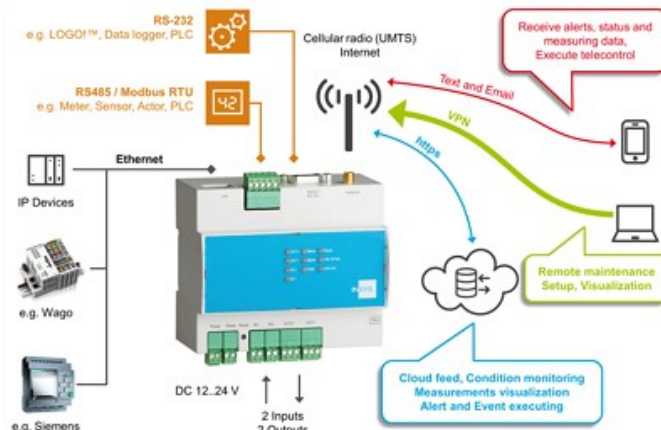



## ADCM- 2650

### VGA CAMERA MODULE WITH LENS AND PROCESSOR



Our Guarantee:

1. Great Image Quality
2. Supply Available for the Duration of Your Product Life
3. We Match/Beat Any Competitor Quotation

Our Camera Modules address a broad spectrum of products. Our complete Camera Module feature sophisticated Image Signal Processing, which enhance the performance of our image sensors. The integrated ISP analyses the scene and automatically optimizes the exposure, color balance, contrast, gamma as well as other subtle imaging parameters such as sharpness and noise filtering in a similar fashion to point and shoot consumer digital cameras. This ease of use coupled with excellent image quality and competitive pricing makes Connectivity Solutions Plus the ideal choice for your Camera Module and Image Sensor needs.

#### Applications:

Medical, Mobile phones, Video phones, Toys, Personal Digital Assistants, Image-enabled appliances, Digital still mini cameras,

## USG Imager USG-2650

### TRANSMITTING IMAGES AND MOTION SIGNAL FROM BUILDINGS AND TUNNELS



A miniaturized board that includes a ADCM-2650 Camera Module, Motion Sensor and a Zigbee Transmitter and Receiver System. The System supports monitoring of locations and personnel detection in buildings, sewers, tunnels, and etc. It consists of one or more sensor nodes and at least one gateway node, which form an ad-hoc, short-haul wireless network. The system components are battery powered and designed to be small, unobtrusive and light weight. The gateway node serves as the system controller. There are two types of sensor nodes: Intrusion Nodes and Imaging Nodes. Intrusion Nodes provide an alert upon detection of human motion within the sensor field of view, whereas imaging nodes are capable of capturing and transmitting imagery of detected events, allowing for remote classification of intruders.

#### Applications:

Rescue Operations, Detecting Motion and Images in Tunnels, Buildings, Building Automation

## Modules for integration into your application

### CELLULAR RADIO, CAMERA MODULES, ZIGBEE IMAGE TRANSMISSION



Ready-to-use integration modules from 1 piece already or customer-specific development of prototypes up to series production incl. free wiring diagram and layout review. Our integration modules provide you with a quick and easy option to integrate a professional data transmission component into your application. Focus on your core competence, conserve your development budget and shorten your time-to-market for the complete solution significantly. Our modules are available ready-to-use for all common transmission technologies and in different variants - and starting from one piece already.



CONNECTIVITY SOLUTIONS PLUS

35111F Newark Boulevard 114

Newark, CA 94560, USA

Phone: 510-739-1940

Email: [sales@connsp.com](mailto:sales@connsp.com)